

# KENDRION

---



**KENDRION** SOLUTIONS

## **Elevation Line**

Spring-applied single-disc brake and  
spring-applied double-disc brake  
for the elevator technology

PRECISION. SAFETY. MOTION.

# Kendrion – The brake experts

**Kendrion stands for high-precision electromagnetic actuator systems and components for passenger cars, commercial vehicles and industrial applications. We are the trusted partner of some of the world's market leaders in the automotive and industrial segments when it comes to designing and producing complex components and customised solutions. Rooted in Germany, headquartered in the Netherlands and listed on the Amsterdam stock exchange, our expertise extends across Europe to the Americas and Asia.**

## **Tradition and progress**

More than one hundred years after the company was founded by Wilhelm Binder, Kendrion is ideally equipped for the challenges and tasks of the future. The company has always held a strong position in the market and is expanding its activities all over the world. In the field of electromagnetism, Kendrion stands for highest quality, innovation and precision.

## **Areas of application for brakes and clutches**

The Kendrion business unit Industrial Drive Systems develops and produces electromagnetic brakes and clutches for industrial drive technology. They are used to accelerate, brake, position, hold and secure moving drive components and loads. Areas of applications for the brakes and clutches can be found mainly in robotics and automation, conveyor technology, tooling machines and production engineering, medical technology and elevator technology.

## **Worldwide availability**

The main location is in Villingen-Schwenningen in southern Germany. However, Industrial Drive Systems has further development and production sites as well as a worldwide sales network at its disposal.

We will find the right brake for your application!



**Safety with trusted brakes**

# About the Elevation Line

**The Elevation Line is comprised of DC operated springapplied single-disc and double-disc brakes which comply with the requirements of the European standard EN 81-1 (safety requirements to be observed in the construction and installation of elevators).**

Owing to the patented safety concept, the usual checks concerning the double-circuit system of spring-applied brakes can be omitted during the technical approval of the elevators. Built-in microswitches are provided for remote interrogation of the brake condition (armature position, degree of wear).

The brake is ideally suited for use in space restricted environments where compact systems comprising of a motor, gearbox and brake are required.

The Elevation Line is preferably used in the field of elevator construction, but it is also ideal for other applications characterised by stringent requirements in terms of brake safety. Electromagnetically operated spring-applied brakes generate the brake torque when voltage is removed.

## Versions

### 76 461..A00

- Torque range 75 to 220 Nm
- Direct current (DC)
- Adjustable torque
- Single-disc brake (holding brake)

### 76 451..A00

- Torque range 280 to 440 Nm
- Direct current (DC)
- Adjustable torque
- Double-disc brake (holding brake)

## Approval

- EN 81-1

## Applications

- Elevator technology
- Lifting and materials handling technology
- Crane construction

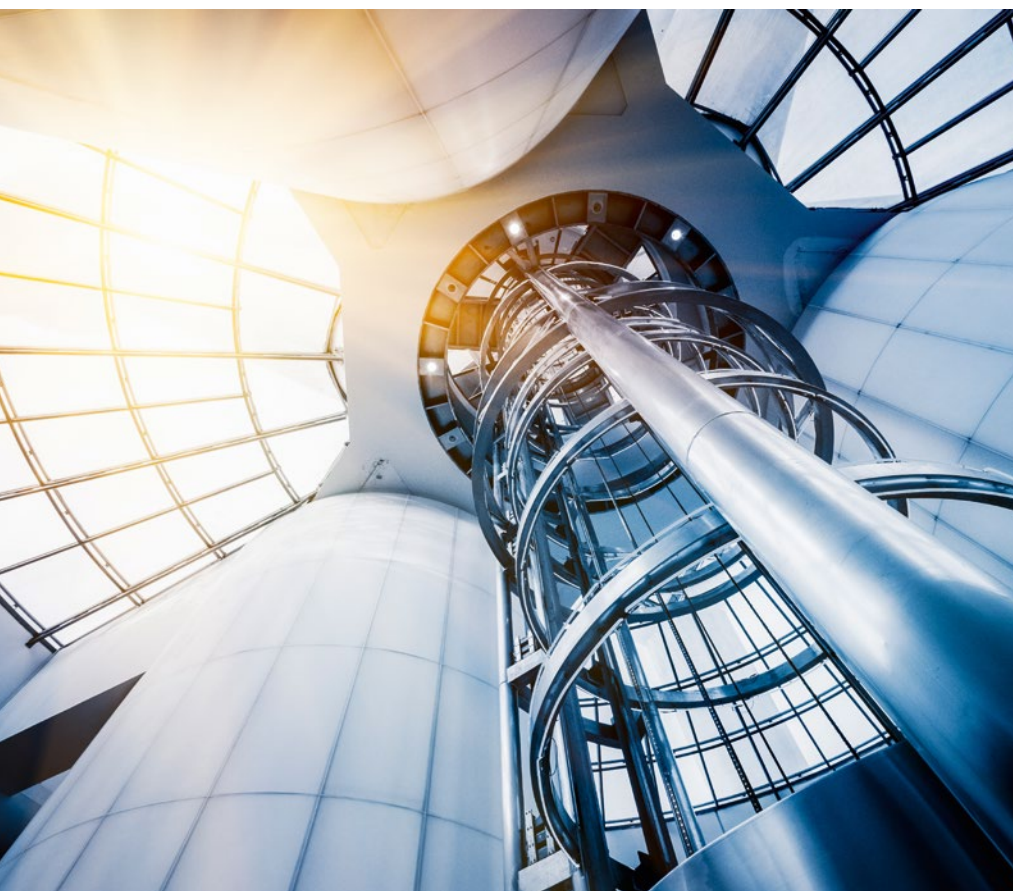

## General information

The Operating instructions must be strictly observed during the set-up of the machine (e.g. motor) and during the start-up, operation and maintenance of the brakes. The state-of-the-art brakes have been designed, built and tested in accordance with the requirements of DIN VDE 0580 concerning electromagnetic devices and components.

Additional information on technical specifications given in the data sheets is included in the operating instructions.

# Technical specifications

## Elevation Line

<b>Versions</b>	76 451..A00 – double-disc brake (holding brake) 76 461..A00 – single-disc brake (holding brake)
<b>Standard rated voltages</b>	205 VDC
<b>Protection</b>	IP44
<b>Thermal class</b>	F
<b>Transmissible torques</b>	75 to 440 Nm
<b>Note</b>	The general information on specification sheets and the applicable operating instructions must be observed. Specifications are subject to change without notice.



Size	Transmissible torque $M_4$ [Nm]	Max. speed $n_{max}$ [min <sup>-1</sup> ]	Max. switching power $P_{max}$ [kJ/h]	Max. switching energy (Z = 1) $W_{max}$ [kJ]	Rated power $P_N$ [W]	Response times		Moment of inertia armature and flange hub $J$ [kgcm <sup>2</sup> ]	Weight $m$ [kg]
						Coupling time $t_1$ [ms]	Disconnection time $t_2$ [ms]		
<b>16</b>	75 – 145	2500	400	65	135 <sup>[1]</sup>	185	280	20	16
<b>19</b>	120 – 220	2500	500	95	230 <sup>[1]</sup>	160	220	45	22
<b>19<sup>[2]</sup></b>	280 – 440	2500	500	155	230 <sup>[1]</sup>	95	260	75	25

<sup>[1]</sup> Duty cycle = 55%, cycle time  $t_7 = 5$  min.

<sup>[2]</sup> Double-disc brake 76 45119A00

# Dimensions type 76 461..A00

## Elevation Line – Spring-applied single-disc brake

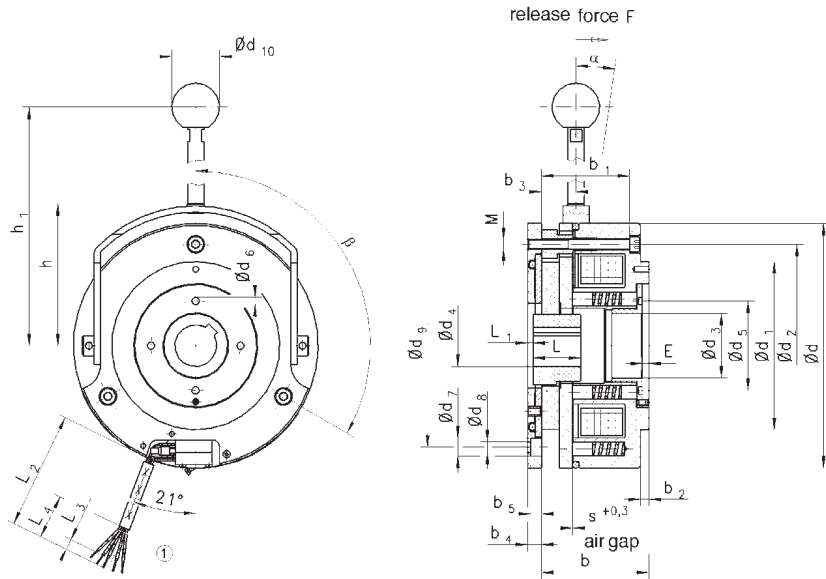

① flying leads 2x0.82mm<sup>2</sup> (brake)  
flying leads 3x0.53mm<sup>2</sup> (microswitch)

Size	d	d <sub>1</sub>	d <sub>2</sub>	d <sub>3</sub>	d <sub>4</sub> (H7)	d <sub>5</sub>	d <sub>6</sub>	d <sub>7</sub>	d <sub>8</sub>	d <sub>9</sub>	d <sub>10</sub>	b	b <sub>1</sub>	b <sub>2</sub>	b <sub>3</sub>
16	205	141	170	54	25 <sup>1)/45<sup>2)</sup></sup>	75	6.1	15	9/3 x 120°	170	40	90	74	7	33
19	232	160	196	66	35 <sup>1)/50<sup>2)</sup></sup>	90	7	15	9/6 x 60°	196	40	97.5	81	6.5	30

Size	b <sub>4</sub>	b <sub>5</sub>	h	h <sub>1</sub>	L	L <sub>1</sub>	L <sub>2</sub>	L <sub>3</sub>	L <sub>4</sub>	s	s <sub>max</sub>	E	M	F <sup>3)</sup> [N]	α	β
16	11.5	9	119	260	40	4.5	850	9	40	0.3	1.1	0-6	3xM8	400	ca. 8°	3x120°
19	11.5	9	133	350	65	4.5	850	9	40	0.3	1.3	0-6	6xM8	400	ca. 12°	6x60°

<sup>[1]</sup> Min. bore with keyway JS9 as per DIN 6885, sheet 1

<sup>[2]</sup> Max. bore with keyway JS9 as per DIN 6885, sheet 1

Supporting keyway over entire length. Shaft ISO fitting k6 (<sup>[1]</sup>,<sup>[2]</sup>)

<sup>[3]</sup> Release force F (approx.) referred to max. transmissible torque (standard).

Dimensions in mm

# Dimensions type 76 451..A00

## Elevation Line – Spring-applied double-disc brake

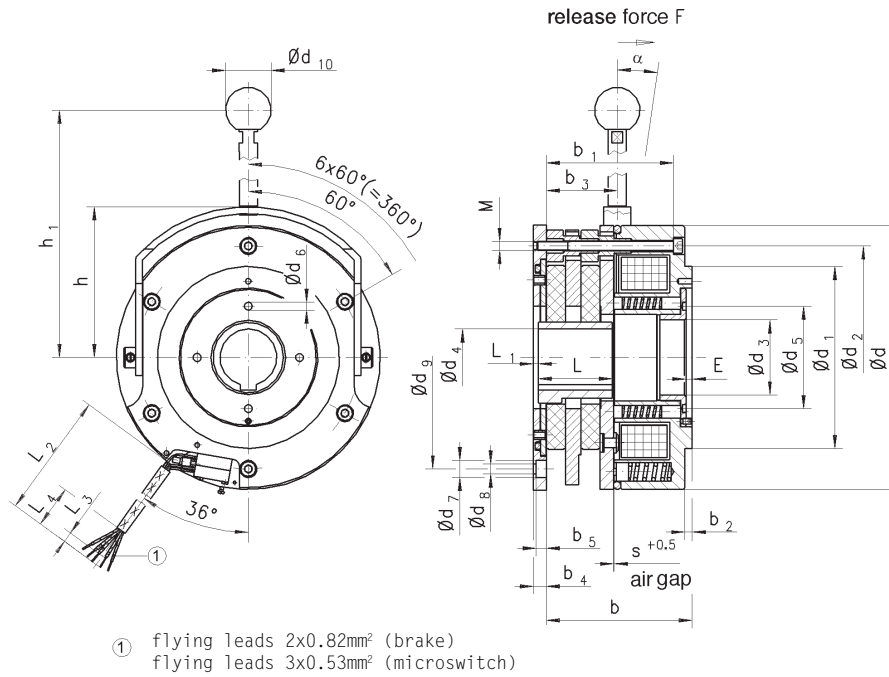

Size	d	d <sub>1</sub>	d <sub>2</sub>	d <sub>3</sub>	d <sub>4</sub> (H7)	d <sub>5</sub>	d <sub>6</sub>	d <sub>7</sub>	d <sub>8</sub>	d <sub>9</sub>	d <sub>10</sub>	b	b <sub>1</sub>	b <sub>2</sub>	b <sub>3</sub>
19	233	160	196	66	45 <sup>(1)</sup> /50 <sup>(2)</sup>	90	7	15	9/6 x 60°	196	40	128	111.5	6.5	62

Size	b <sub>4</sub>	b <sub>5</sub>	h	h <sub>1</sub>	L	L <sub>1</sub>	L <sub>2</sub>	L <sub>3</sub>	L <sub>4</sub>	s	s <sub>max</sub>	E	M	F <sup>(3)</sup> [N]	$\alpha$
19	11.5	9	133	350	65	4.5	850	9	40	0.4	1.4	0-6	6xM8	400	ca. 10°

<sup>(1)</sup> Min. bore with keyway JS9 as per DIN 6885, sheet 1

<sup>(2)</sup> Max. bore with keyway JS9 as per DIN 6885, sheet 1  
Supporting keyway over entire length. Shaft ISO fitting k6 (<sup>(1)</sup>,<sup>(2)</sup>)

<sup>(3)</sup> Release force F (approx.) referred to max. transmissible torque (standard).

Dimensions in mm



## Individual customer solutions

Specially tailored to your needs

**Automation solutions have become indispensable in both industry and our everyday lives. Mechatronics helps achieve further expansion of these solutions, and increases the range of applications. In many cases, electromagnetic brakes meet the necessary safety requirements, allowing loads to be securely held and ensuring safe braking in an emergency.**

Catering to different market demands while also ensuring product standardization is a challenge that Kendrion relishes. Customized solutions can be developed and manufactured on the basis of an existing portfolio of products, the prerequisite being the analysis and understanding of industry-specific customer requirements. With the right product range and a high level of expertise in automation technology, robotics, machine building and elevator engineering, Kendrion Industrial Drive Systems is your dependable partner, providing the ideal individual brake solution for any application.

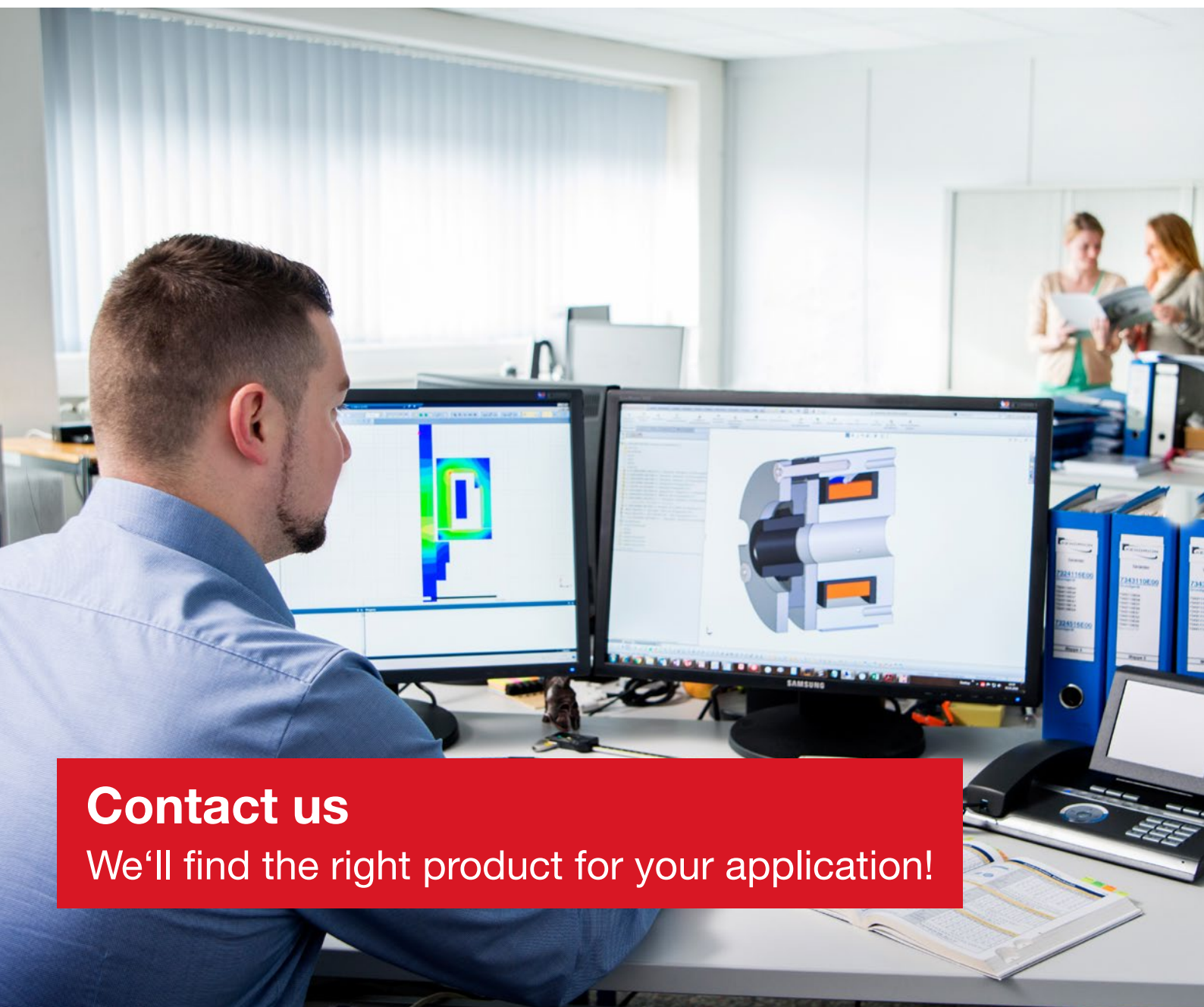

**Contact us**

**We'll find the right product for your application!**

## **Kendrion (Villingen) GmbH**

---

Wilhelm-Binder-Strasse 4-6  
78048 Villingen-Schwenningen  
Germany

T +49 7721 877-0  
F +49 7721 877-1462

[sales-ids@kendrion.com](mailto:sales-ids@kendrion.com)  
[www.kendrion-ids.com](http://www.kendrion-ids.com)

